

Exploring the Dynamic Nexus between Value Based Education and Holistic Community Development: A Model Based Approach

Priyanka Singh¹, Aniruddh Vijay² and Dr. Sanjay Bhushan³

Research Scholar, Department of Management; Faculty of Social Sciences;
aniruddhvijay@gmail.com¹

Research Scholar, Department of Management; Faculty of Social Sciences;
priyanka.singh.0415@gmail.com²

Associate Professor, Department of Management, Faculty of Social Sciences;
bhushan.sanjay@rediffmail.com³

Dayalbagh Educational Institute (Deemed University), Agra^{1, 2 and 3}

Abstract

Education is influential means of bringing progressive development in human behavior. Value based education is one of the means for developing sense of humanism and deep concern for the society and the nation. Individual can build up moral, ethical, spiritual and social dimensions of an individual which are often undermined in formal education through value based education. Educators have envisioned education for the liberation of human mind, development of consciousness and modernization of society. New education system should essentially achieve all these factors and able to meet new challenges whereas on the other hand, community based development need support and coalition of interest and thoughts of individual, groups and representatives. Community building includes variety of approaches related to community economic development and community organization. Quality education aims towards empowerment of the individuals and assumes responsibility to build a sustainable future. Value based education gives a direction to an individual which is a social framework ethically acceptable, economically viable, ecologically justifiable, socially responsible and universally accessible. Therefore, balance between technology and human values is required for holistic community development. Value based education is need of the day for transforming an individual into holistic personality. The present paper is an attempt to explore the role of value based education in holistic community development. The linkages of value based education with holistic community development are visualized with the help of system dynamics approach which is an integration of causal modeling and stock flow modeling.

Keywords: *Value Based Education, Holistic Community Development, Stock Flow*

Introduction

At present, educational system is working to ensure better knowledge and skills for a productive society. The focus is more towards the large institutions of urban area as their mission is to provide quality education and achieving academic success. The paradigm shift in economy has created demand for highly skilled and literate workers has created a challenge for the education system which provide chance to take benefit of opportunities. Report submitted in 1999 for Education Summit declares that “The real challenge for public education is to lift the academic proficiency of more than 12 million impoverished and disadvantaged young people who struggle with reading, mathematics, and science. These children have more opportunities to gain from a system that expects more from them.” Basic perception for achieving higher academic success is investing more resources especially in urban institution. The current political climate and bottom-line orientation gives more emphasis on standardized test score but there are many other ways to measure learning which is realized by professors and administrators. Educational institutions are improving results by aligning all aspects such as lectures, services, involvement of parents, more focus on students and lastly academic achievements.

Holistic Community Development

With the passage of time, people are working together to improve the environmental and living conditions. Various organizations involve neighborhood based organizations, community development corporations and other groups make themselves part of problem solving and strengthen local communities whereas sometimes these groups work independently with coalition. The groups help in addressing issues and solve it according to the government and society. Community building includes variety of approaches such as community economic development and community organizing where, on one hand organizations’ initiatives help in building political and social resources by empowering inhabitants to mobilize them and on other hand Community economic development idea builds economic and physical capital by increasing physical and economic infrastructure and various other opportunities through job creation, basic needs, transportation and other initiatives.

“Community building refers to consistent, self-renewing efforts made by residents and professionals to engage in collective action, aimed at problem-solving and enrichment that creates new or strengthened social networks, new capacities for collective action and support, new standards and expectations for life in the community.” (Source: Rockefeller Foundation Publication, 2014).

Community developers emphasize on relevance of personal and institutional relationship for change which is again possible through coalition due to which community can avail quality housing, adequate resources, hygienic environment and jobs creation opportunities. Community developers explore new demands and situations to employ range of strategies from cooperation for confrontation and achieving objectives.

Literature Review

Future development of any country lies on its youth but now-a-days youth are declining in terms of involvement in non violence, social deeds and respect for the environment. The rationale behind such decline is absence of value based education, family and social environment system which also involve role of media which skewed the picture (J. Jindal, 2013). The requirement of value based education arises on international level. The activities like violence, individualism, hatred, terrorism, etc. are turning as a challenge for holistic community development (C. M. Yogi, 2009) while Indian cultural system is soiled by spiritual values. The values if not imbibe in the life of individual through education; it will loose its worth. Therefore, evolving morality in educational curriculum is essential to achieve the esteemed goals of humanism, socialism and secularism (S. Gupta, 2003). The inculcation of values helps in combating injustice, religious fanaticism and exploitation. So, value based education should become an integral part of education as it helps in character building, ethics and universal perception (Programme of Action NPE, 1992). Sekhar and Emmaniel (2012) have discussed the paradigm shift in approach of teaching- learning process from teacher centric to student centric. Educators are also adopting appropriate pedagogical strategies of digital technological for teaching learning processes. Educators should also be flexible to accept these changes for improvement in the performance level of students. Education through Information and Communication Technology (ICT) become national priority tool to increase access specifically in the higher education. It supports in modernization combined with spiritual touch develops an individual holistically so that they can become more skilled and powerful enough as a major contributor for their community development. Quality in education will encompass the entire community, in building awareness, consciousness, and motivation among community members. It also acts as a communication channel among the internal and external community stakeholders, which helps to communicate the vision of the community. Such increased level of awareness and empowerment within the community is aimed at helping community members to recognize the upstream causes of issues pertaining to their community. Being able to assess issues within their own community, can introduce community members to the potentials they exhibit to demonstrate their own understanding in creative and innovative ways. It will encourage self-organization within the community, build trust, and motivate community members to recognize their intrinsic role in the development process (Dahir, Kang and Bisley, 2009). The word development can be defined as a process that increases alternatives such as new choices, diversification, thinking about emerging issues differently and anticipating change (Christenson et. al., 1989). Development includes shifts and consistent enhancement - a directed attempt to promote the level of participation, flexibility, equity, attitudes, the function of institutions and the quality of life (Shaffer, 1989). Community development creates the five assets for a community-physical, financial, human, social and environmental and related development cannot be reality in the absence of value based education which can show a path for the holistic community development by guiding on the created five parameters for development (Jim Cavaye, 2002).

Conceptual Model

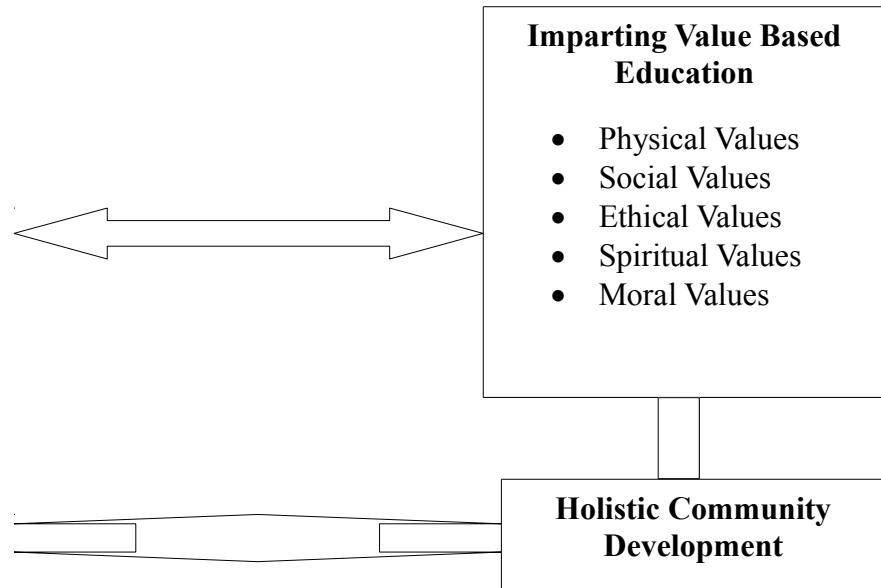

Under the broader head of this study, researchers have outlined the various challenges in holistic community development, explored the solutions for community development through value based education and identified dynamic nexus between value based education and holistic community development. The nature of present study is exploratory and descriptive, where data collection has been done from various secondary sources such as published research papers in international and national journals, websites, published reports, newspapers and books. Researchers have used content analysis technique to analyze the collected secondary data. Further, the researchers have also used System Dynamics technique to form a stock flow diagram for desired community development model.

Challenges Ahead

The Challenge of Confidence

The difficulties faced by many communities in maintaining action is not only due to lack of access to funding, venture capital or limits to community engagement but also due to people struggle discriminate direction for action and lack of confidence to act individually or as communities. Development plan needs to be better addressed for community confidence with providing both tangible support and encouraging coach and support for morale and confidence.

The Challenge of Perception

Community development agencies need to communicate with communities in a way that help recognizing perceptions and beliefs of local people. Attitudes towards the community helps in determine action for future than the possibilities. Communities may struggle for change but they perceive they cannot make positive steps are again crucial challenge. These perceptions include vision about the future prospects, image of a community development initiative itself and current community situation.

The Challenge of Participation

Holistic community development program need to embrace new forms of community involvement like temporary commitments, networks of existing community groups, coalitions to engage people with inadequate volunteer capacity and persuade broader spectrum of community participation. It also need to involve local residents in prioritizing concern based on level of motivation and create smooth ways for people to act on existing problem. This participative democracy must retain legitimacy to add value.

Challenges for Government

The development schedule of government involves some challenges such as how to foster rural and regional development, role of state bureaucracy in developing lower income section, implementing all schemes of present government within the specified budget and trusting the words of people who speaks for the society but speaks only for their interest (Gray 1991).

Building Linkages between Value Based Education and Holistic Community Development

Community builders and educators are discovering the commonality of education and community development. Educational institutions are developing various plans to improve the performance of students. Especially educational institutions of urban areas are appearing for opportunities by focusing on family support, youth development and delivery of social services which results in breeze nationally, many partnerships of various organizations to bring range of activities, opportunities for student learning and strengthening families and communities. Community development is essentially supported by value based education. Value Based Education imparts certain indispensable values like spiritual, ethical, moral, cultural, social values for an individual's holistic development and makes him citizen. It also includes physical health, etiquettes, civic rights and duties social behaviour etc. Value driven education to the community is the only solution for improving infrastructure, environment or business expansion. Community based development begins with consideration of the society choice for visioning community level and strategic regional planning and this includes the expression of values of the society. Value based education helps in determining development priorities such as environment or infrastructure different priorities in community's values. Value based education helps in perceiving opportunities and assets. Holistic community development programs required to be more precisely incorporate community values and robust processes with which society can raise, discuss and manage conflicts relating to community values which is difficult due to three challenges: First, complex definition of community values clouded by cultural rules and restricted power. Values inspire behavior and opinion underline future prosperity which are seldom expressed and difficult to agree. Many countries are struggling with value based decisions about rural and regional development. Some value based questions are as follows: Should rural towns be allowed to destroy if economic forces order? Should economic forces reducing rural viability be alleviated by governments? What is the correct balance of policy and resources between rural and urban areas?

Second, community values are varied and intrinsically involve conflict; members hold very diverse values based on their background and experience. Value based education gives a sense to understand and accept diverse culture, religion and respect them which helps in managing conflict over community values.

Third, community values are dynamic. Forces like de-traditionalization and globalization are changing the value systems of past generations; shifting patterns of communal authority, altering social engagement and commitment to local institutions (Gray and Lawrence). Agrarian values for instance independence, self-reliance, hard work and the substance of family and community are declining (Halpin and Martin, 1996). Value based education helps in making holistic personality development of an individual which help in holistic community development.

Dynamic Model for Holistic Community Development

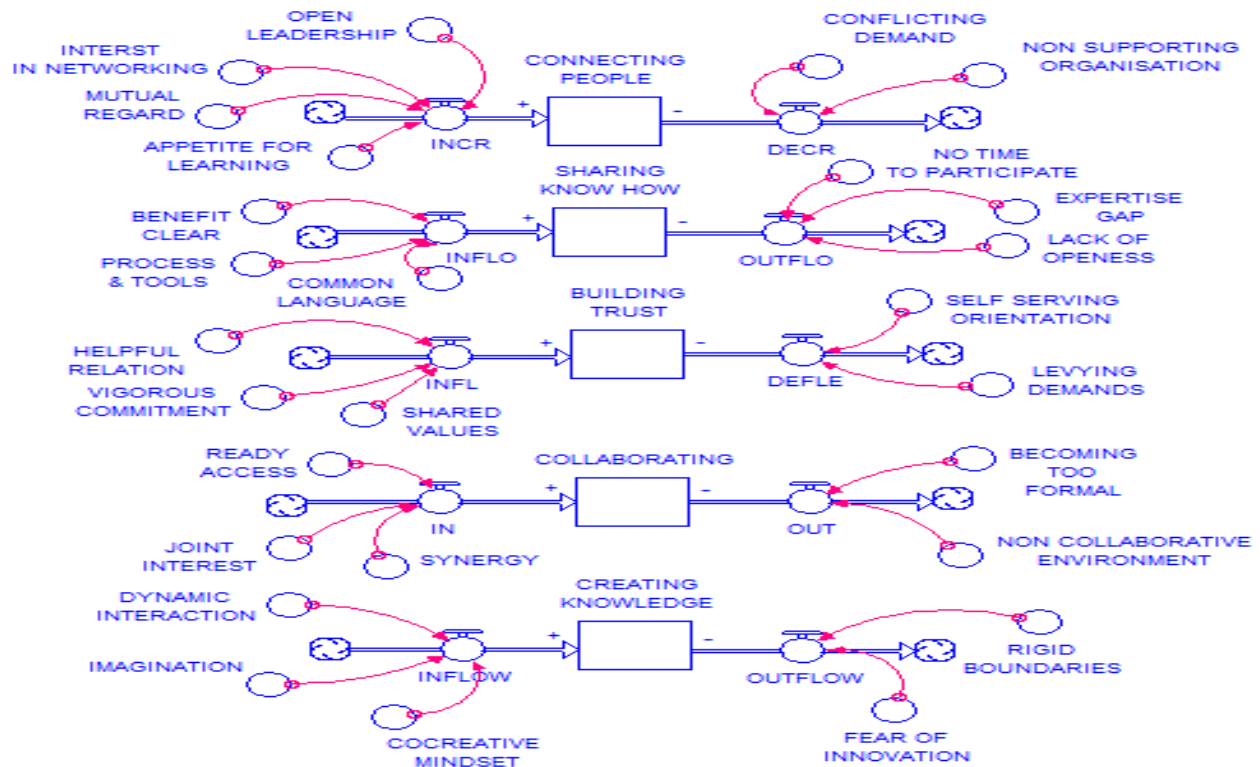

Above shown dynamic model depicts the various determinants impacting either positively/negatively to the stock variables which are connecting people, sharing know how, building trust, collaboration and creating knowledge; effective implication of these variables can assist in the development of communities.

Connecting people is a major variable which influences the level of holistic community development as it leads to the spreading the thought of an individual with the galaxy of groups. Researchers have identified four determinants of connecting people; they are: open leadership, networking interest, mutual regard and appetite for learning. These determinants positively influences the level of connectivity among the people while on the other hand, conflicting demand and non-supportive organizations impacts negatively on level of connectivity among the local residents.

Sharing know how is one of the indispensable methods which contributes in imparting more technical skills and making development of the community by way of what one knows about creating awareness. Researchers have identified various determinants of sharing know how which positively influences the level of sharing know how in the community. These determinants

are clear benefits or agenda, process and tools, common language and common goal on the other hand, lack of openness to share, no time to participate and expertise gap becomes negatively influencing variables for sharing know how.

Trust is the key parameter which eases the attainment of any goal therefore, it can be stated that trust building is essential before commencement of any framed plan. Here, researcher has identified vigorous commitment, shared values and helpful relations as the determinants which positively influence the level of trust among the residents of a particular community whereas on the other hand, levying demands and self serving orientation are found to be determinants which are found to be as challenges for building trust.

Collaboration is one of the major indicators for the holistic community development as it enhances the results of efforts made by the collaborators. Determinants which are enhancing the level of collaborations are ready access, joint interest and synergy whereas determinants which are identified as challenges for collaborations are more formality in the nature creates distances with the stakeholders and non-collaborative environment in any industry also leads no collaborations with the others hence productivity, efficiency and profitability remains same.

Creating Knowledge is a task which needs lot of exercise before transforming a concept in to knowledge. Determinants which are helping in knowledge creation are creative mindset: as innovative knowledge can be derived out when the mind is also having the same characteristics else it would become more difficult to create new knowledge, further good imagination skills and dynamic interaction are also essential for creating new knowledge. On the other hand, rigid boundaries and fear of innovation are the determinants which creates barriers in knowledge creation as if any individual having fear of innovation can never think to take any associated task with knowledge creation and rigidity of mindset believes that present knowledge is sufficient and there is no need to work upon creating knowledge. Therefore, it can be stated that these two are the determinants which negatively influences the level of creating knowledge.

It can be summed up that by goal of holistic community development can be achieved by interlinking stock variables: connecting people, sharing know how, building trust, collaboration and creating knowledge. If proper focus can be given to nourish all the inflow variables which are positively contributing in the development of associated determinants and strategies can be employed to mitigate the level of outflow determinants which are causing hurdles for their associated stock variables then the path to achieve stated goal will become easier than the real.

Recommendations and Conclusion

A strategic approach to community based development should operate across all area with strengthening regional community networks and appropriate links through incorporating value based education at all levels nationally. Community based development funding should be adequate to maintain changes in the level of community strengths and empowering nation and especially in deprived areas. Community based development should be delivered and managed to the maximum standards. Community based development should be promoted in such a way that It recognize nationally with clear basis in methods, values and outcomes. High-quality community based development training should be available at all levels and region according to their requirements with all experienced practitioners and talented new entrants recruited.

Current approaches to holistic community development are inadequate. There is a need of comprehensive agenda for information dissemination, service delivery and discrete initiatives to include additional approaches which further involve access, partnership, coordination, new

assumptions and fostering local motivation. The requirement of working on the root level will only help in making the development which includes working on the upbringing of students and provide them value based education which nurtures them as a holistic citizen for the society. Value based education helps in making development of student personally, mentally, socially, sense for environment and intellectually. Once an individual become a good citizen then naturally he works in right and justifying way to improve the community and innovative ideas to make community development. Community based development promotes social inclusion, social justice and participation. Social inclusion helps in building individual and community capacity to generate economic, social and opportunities. Community based development helps in making people more participative and motivate in the developmental program for the society. Community based development is an approach to change that depends on building solidarity and capacity of people to work together on concern on limited resources. Community based development involves collaboration between interest citizens, groups and government. Strong communities have capacity to identify causes for potential problems, act on those causes, take preventative action and learn form the outcome.

References

- Ainley, M. (2006). Connecting with learning: Motivation, affect and cognition in interest processes. *Educational Psychology Review*, 18, 391–405.
- Aspen Institute (1996). *Measuring Community Capacity Building: A Workbook-in-Progress for Rural Communities*. The Aspen Institute, Washington D.C.
- Balaji, Ranjani (2013). Value-Based Education: Professional Development vital towards effective integration. *Journal of Research & Method in Education*. Volume 1(1).PP 17-20.
- Biggs, S. (1999) *Community Capacity Building in Queensland: The Queensland Government Service Delivery Project*. Unpublished paper. Office of Rural Communities, Brisbane, Queensland.
- Cavaye, J. M. (1999). *The Role of Government in Community Capacity Building*. Queensland Government Information Series Q199804. Queensland Government, Brisbane.
- Cavazos, L., F. (2002). *Emphasizing Performance Goals and high-quality education for all students*. *Phi Delta Kappan*. 83 (9).
- Chanan g., garratt C. and West a. (2000), *The New Community Strategies: How to Involve Local People*. Community development Foundation, London.
- Christenson J.A., Fendley, K. and Robinson J.W. (1989). *Community Development*. In *Community Development in Perspective*, edited by J.A. Christenson and J.W. Robinson, pp. 3-25. Ames: Iowa State University Press.
- Combes, Bernard (2003). *Global Perspectives on Values Education*. Keynote address at the Giving Value to Values Education Symposium Hong Kong, October 2003.
- Dahir A. A., Kang H. J. and Bisley N. (2009). *A Holistic Approach to Sustainable Community Development in the Developing World*. Blekinge Institute of Technology, Karlskrona, Sweden.
- Flora, C.B. (1997). *Enhancing Community Capitals: The Optimization Equation*. *Rural Development News*, The North Central Regional Center for Rural Development 21(1): 1-3.
- Gillard, E. (2000). *Understanding Change*. Department of Primary Industries, Queensland Government, Brisbane, Queensland, Australia.

- Government of Ireland (2000), White Paper on the Community and Voluntary Sector and its Relationship with the State, stationery office, Dublin.
- Gray, I. (1991) *Politics in Place: Social Power Relations in an Australian Country Town*, Cambridge: Cambridge University Press.
- Gray, I. and Lawrence, G. (2000). Reflexivity and Neo liberalism in Regional Australia, Sociological Sites/Sights TASA 2000 Conference, Flinders University, Adelaide, December.
- Gray, I. and Lawrence (1999), G. Forthcoming. *A Future for Regional Australia: Escaping Global Misfortune*, Cambridge University Press, Cambridge.
- Halpin, D. and Martin, P. (1996). Agrarianism and Farmer Representation: Ideology in Australian Agriculture, in Lawrence, G., Lyons, K. and Momtaz, S. (eds) *Social Change in Rural Australia: Perspectives from the Social Sciences*, Rockhampton, Queensland: Rural Social and Economic Research Centre, Central Queensland University: 9-24.
- Jindal, J. (2013). Value Based Education – Need of the Day. *International Journal of Engineering Research in Management & Technology*. Volume 2 (9). PP 24-26.
- Lawrence, G. and Gray, I. (2000). The Myths of Modern Agriculture: Australian Rural Production in the 21st Century, in Pritchard, B. and McManus, P. (eds) *Land of Discontent: the Dynamics of Change in Rural and Regional Australia*, UNSW Press, Sydney: 33-51.
- Loney, M. (1983). *Community against Government - The British Community Development Project 1968-78*. London: Heinemann.
- Lovat, T. (2011). Values education and holistic learning: Updated research perspectives. *International Journal of Educational Research*, 50, 148-152.
- Sekhar, S. C. and Emmaniel, R. (2012). Impart Value Education. *International Journal of Academic Research in Progressive Education and Development*. Volume 1 (1). PP 355-362.
- Shaffer, R. E. (1989). *Community Economics. Economics Structure and Change in Smaller Communities*. Iowa State University Press, Ames, Iowa.
- Yogi, C. M. (2009). *Value Based Education. Save the children and curriculum development centre*.